

TSI 150CCE



COMPACT CRAWLER-MOUNTED SONIC DRILL RIG

Terra Sonic brings its innovation and proven power to the European Market. The CE-certified rig's compact footprint, remote-control tracking and track-mounted design make it perfect for accessing tight areas, indoor spaces and tough terrain.



FEATURES

- Exclusive Sonic Oscillator uses 150 Hz to generate resonant sonic energy
- Standard 8.81 m (28 ft 11 in) long mast
- The Rig has 4.40 m (14 ft 5 in) of Stroke
- Mast accommodates 3.00 m (10 ft) sections of tooling or 1.50 m (5 ft) with optional short mast
- Angle drills between vertical and nearly horizontal
- Rated drilling depth of 304.8 m (1,000 ft) depending on lithology and casing design





SONIC HEAD SPECIFICATIONS

Sonic Head Model	TSi 150
Oscillator Frequency	0-150 Hz
Oscillator Output Force	222 kN (50,000 lbf)
Max Torque (high torque/low speed)	6,341 Nm (4,677 ft-lb)
Rotation Speed (low speed/high torque)	0 to 62 rpm

TRANSPORT DIMENSIONS AND WEIGHT

Width	2.00 m (6 ft 7 in)
Length	8.73 m (28 ft 8 in)
Height	3.30 m (10 ft 10 in)
Weight	17,000 kg (37,478 lb)
Ground Clearance	10 1/2 in (26.7 cm)

DECK SPECIFICATIONS

Jack Legs	Four Hydraulic Stabilizers, Complete with Check Valve and Support Plate
Jack Legs Travel/Lift	Stroke 120x100x70 C = 500 mm (19-5/8 in), Lifting Force 18,500 kg (40,785 lb) each
Slide Base/Wiggle Tail	Front/Back Translation 150 mm (5-7/8 in); Lateral Translation 150 mm (5-7/8 in)



MAST SPECIFICATIONS	
Head Travel/Stroke	4.40 m (14 ft 5 in)
Head Travel Speed	0 to 47.3 m/min (0 to 155 ft/min)
Drilling Angle	45° to 90°
Upper Jib Boom and Hoist	Rotation Angle 180°; Telescopic Stroke 500 mm (19-5/8 in); 13 kN (2,921 lbf) Capacity, 15 m (49 ft 2-1/2 in) of Ø 10 mm (3/8 in) Steel Cable
Mast Lock	Manual Mast Lock in Vertical Position, Manual Adjustable Tie Rod in Angle Position
Feed System	Hydraulic Operated Feed Frame Using Half Leaf Chain Length and Rollers as Conventional Hydraulic Cylinder/Chain Method
Hose Carrier	Mast Integrated Hose Management System with Accessible Bulkheads
Safety Cage	Rotation Guard with Interlocking System and Restricted Operating Mode (ROM)
Work Lights	LED on Mast and Control Panel

RIG PERFORMANCE SPECIFICATIONS	
Rated Drill Depth	Up to 304.8 m (1,000 ft) Depending on Lithology and Casing Design
Max Drilling Diameter	305 mm (12 in) Casing
Pull Back Force	80 kN (17,985 lbf)
Down Force	58 kN (10,566 lbf)
Max Tooling Length	3 m (10 ft)



HYDRAULIC SYSTEM SPECIFICATIONS

Hydraulic Oil Capacity	565 L (149 gal)
Hydraulic Cooling System	70.3 kW @ 379 L/min (240,000 Btu/hr @ 100 gpm) and 14.7 kW @ 76 L/min (50,000 Btu/hr @ 20 gpm) for Sonic Head Lubrication
Variable Displacement Pump	Load Sense Piston Pumps with Pilot Controlled Valves
Pilot Hydraulic Controls	
Manual Setup Functions	

ENGINE SPECIFICATIONS

Engine	Deutz, Model TCD 6.1 L6, Diesel, Stage V
Engine Power	245 hp (180 kW)
Fuel Capacity for Drilling/Transport	40 gal (150 L)
Engine Monitor Mounted in Rig Control Panel	

BREAKOUT WRENCH SPECIFICATIONS

Top and Bottom Wrenches	Dual Clamping Cylinders
Bottom Wrench Clamping Cylinders	Lock Valves Incorporated in Hydraulic Circuit
Wrench Clamp Force	Adjustable Pressure Control Preset at 153.4 kN (34,500 lbf)
Breakout Torque	41,157 N-m (30,365 ft-lb) with Dual Cylinders
Wrench Size Range	76 mm (3 in) to 305 mm (12 in)
Wrench Travel/Swing	19°
Standard Hardened Teeth Inserts	

TRIPLEX WATER/MUD PUMP SYSTEM

Pump Type	Deck Mounted and Enclosed FMC W1122 Bean Pump
Output Pressure	69 bar (1,000 psi) with Relief Valve Set at 34.5 bar (500 psi)



TRIPLEX WATER/MUD PUMP SYSTEM

Water Meter	LED Readout
Max Flow Rate	200 L/min (53 gpm)

OTHER ITEMS

Full Toolbox	Complete with tools for drilling rig maintenance
Technical Information	Rig supplied with operation and maintenance manual, paper and interactive spare parts catalogue and CE declaration of conformity.

RIG OPTIONS

Fully Radio Remote Control Panel
Stainless Steel Water Tank
SPT
Wire Line Winch
Tow Bar Plate
Pressure Washer with Hosing
Generator/Welder
Progressive Cavity Grout Pump
Engine Fluids Heating System
Casing Clamp (3rd wrench)
Dual Head Diamond Coring Option
Wider Tracks to Reduce Ground Pressure
Hydraulic Pipe Handling System

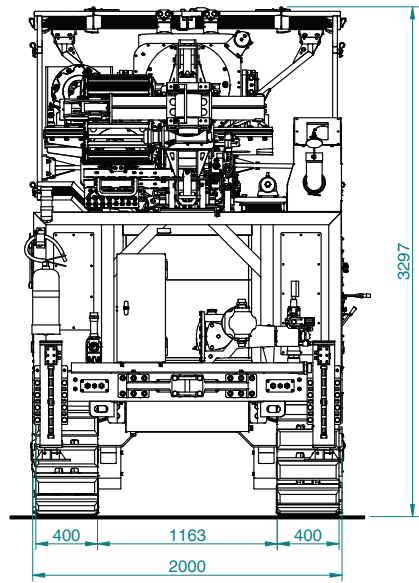
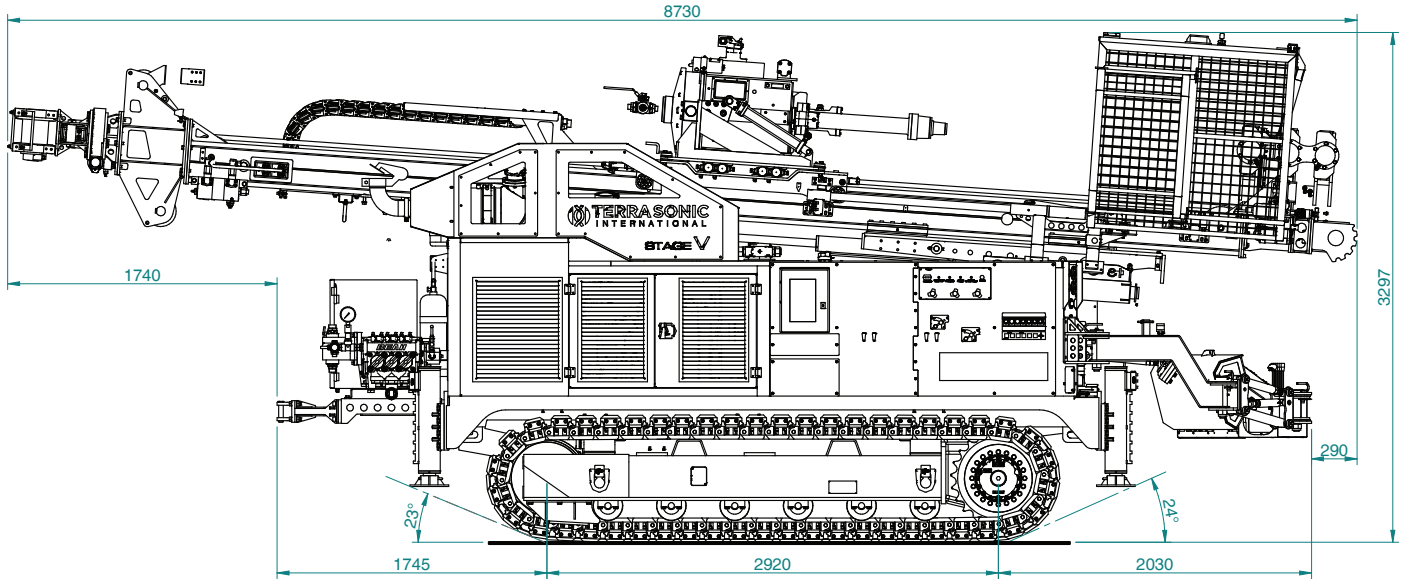

*All dimensional measurements noted in millimeters (mm).

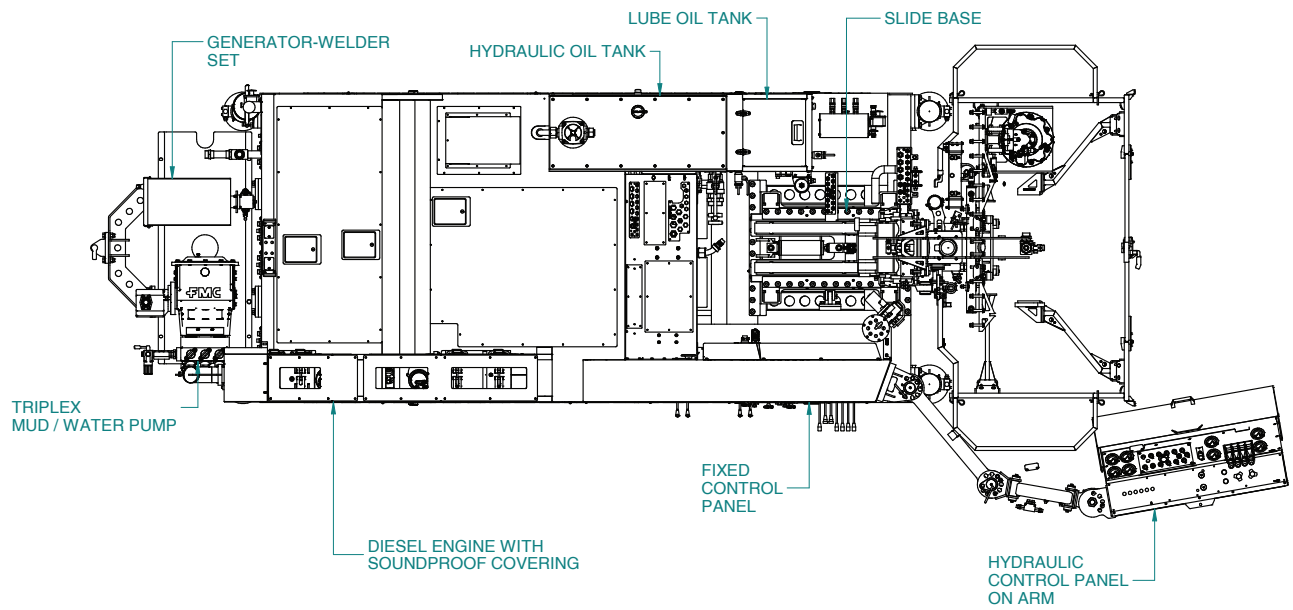

*All dimensional measurements noted in millimeters (mm).

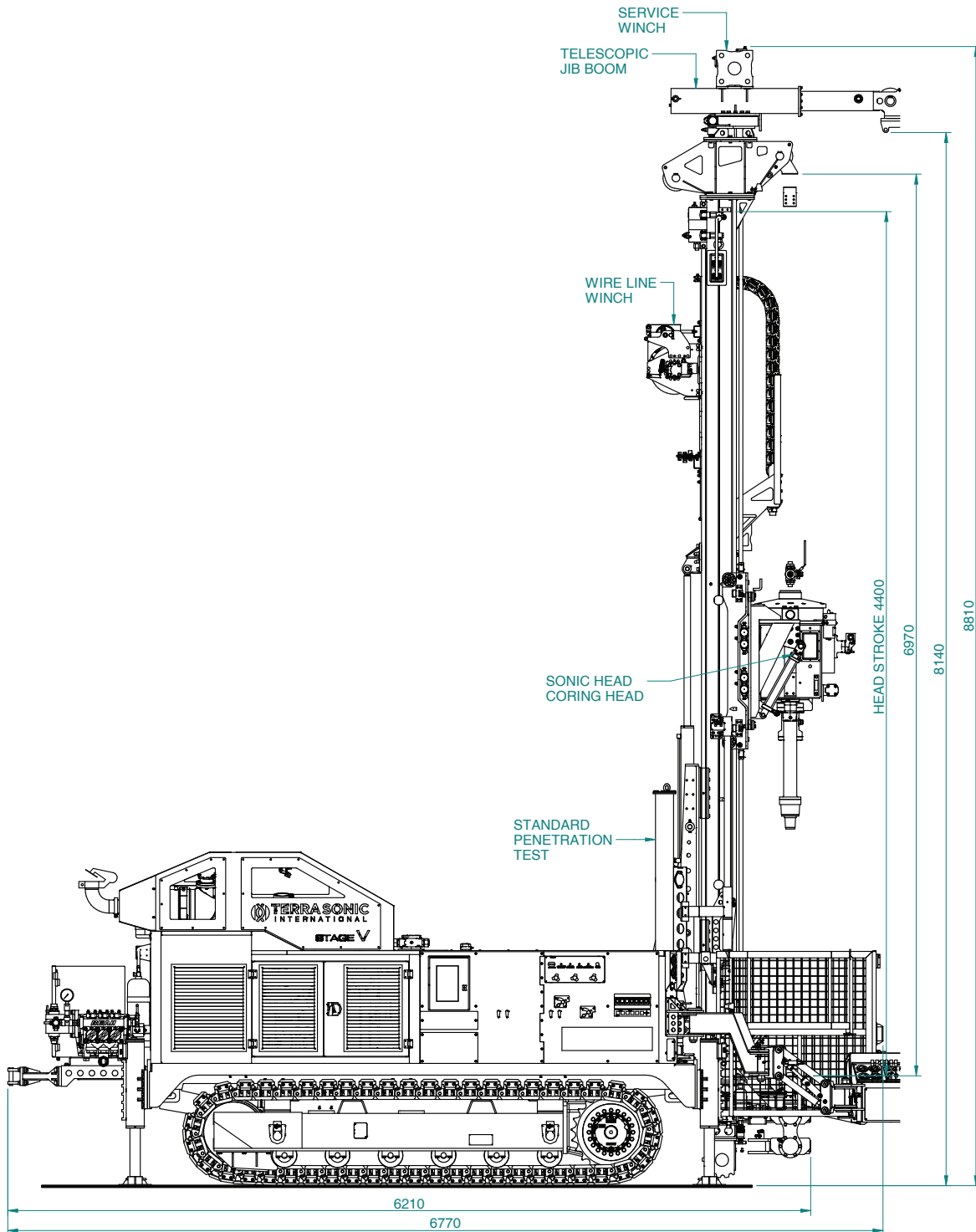

*All dimensional measurements noted in millimeters (mm).

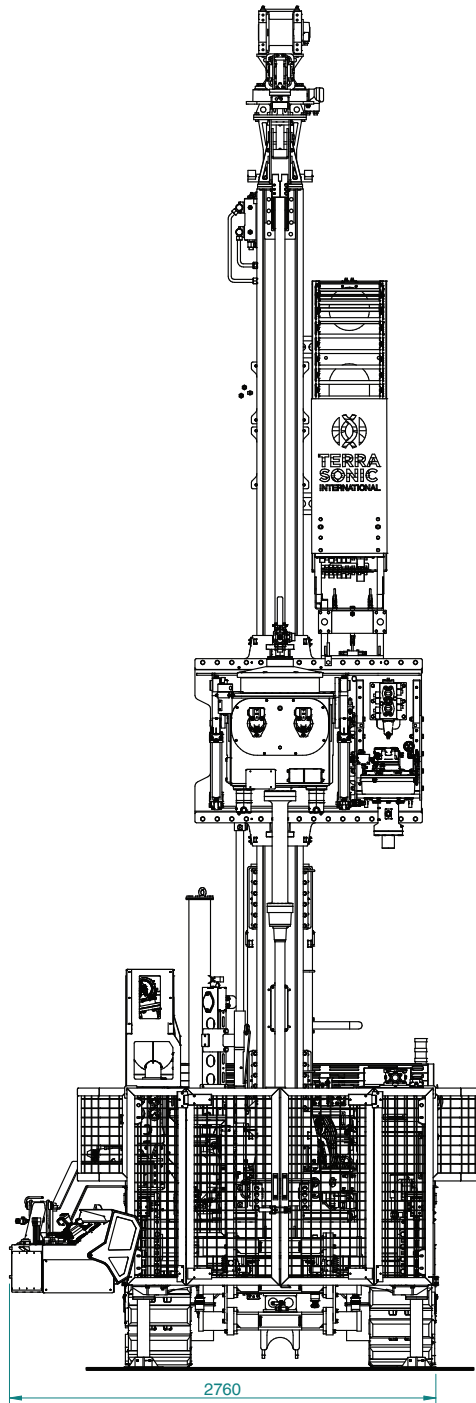

*All dimensional measurements noted in millimeters (mm).